

K531 DIAPHRAGM VALVE - FAILSAFE MODEL

NO.	DESCRIPTION	PART NO.	QTY.
32	SHAFT	1073296 (V531-532)	1
33	LOWER DIAPHRAGM PLATE	1073290 (V531-446)	1
34	O-RING	BUNA N	1071705 (ORB-232)
		FKM	1071825 (ORV-232)
35	UPPER DIAPHRAGM PLATE	1073289 (V531-441)	1
36	CAP ASSEMBLY - 30#	1071263 (K531-F53)	1
	CAP ASSEMBLY - 60#	1071264 (K531-F56)	
	CAP ASSEMBLY - 100#	1071262 (K531-F51)	

NOTE:
DUE TO SPRING ASSEMBLY REQUIREMENTS,
CAP ASSEMBLY SOLD AS ASSEMBLY ONLY.

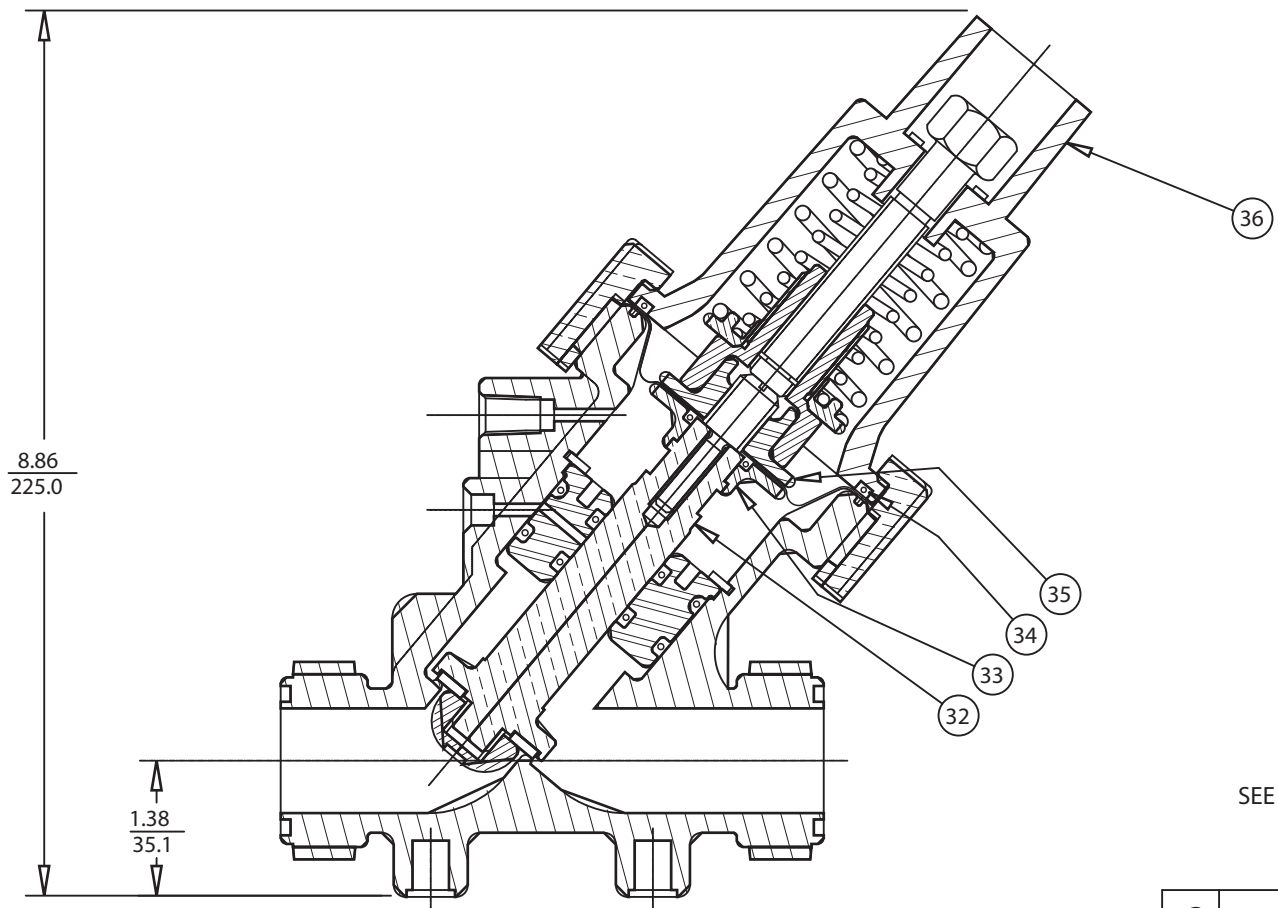

- 1079700 (K531-X203-14000) (30 PSI - 2 BAR)
- 1071291 (K531-X204-14000) (60 PSI - 4 BAR)
- 1071294 (K531-X205-14000) (100 PSI - 7 BAR)

FAILSAFE CLOSED

INCHES
MILLIMETERS

SEE DWG. NO. 1084007 FOR STANDARD MODEL

FORM NO. 1078167

G	SEE REVERSE SIDE	1715	MSM	24JUL07	SMN
REV	DESCRIPTION	ECO	DWN	DATE	APVD
		16605 West Victor Rd New Berlin, WI 53151 262-326-0100 www.aq-matic.com			
SERIES 531 DIAPHRAGM VALVE FAILSAFE MODEL					
DRAWN	JWB	DATE	26JUN01	DRAWING NO.	1084008